

Board Cameras



Board Cameras

Pinhole Cameras

JBC-902HB

1/3" B/W Board Camera with Metal Casing

JBC-906HB

1/3" B/W Board Camera with Metal Casing

JBC-906HHB

1/3" Hi-Res. B/W Board Camera with Metal Casing

Specification

| Model | JBC-902HB | JBC-906HB | JBC-906HHB |
|-----------------------|---|---|---|
| Pick Up Element | 1/3" LG CCD | 1/3" SONY Super HAD CCD | 1/3" SONY Super HAD CCD |
| Picture Element | EIA: 512(H) x 492(V) CCIR: 512(H) x 582(V) | EIA: 510(H) x 492(V) CCIR: 500(H) x 582(V) | EIA: 768(H) x 494(V) CCIR: 752(H) x 582(V) |
| Horizontal Frequency | EIA: 15.750 KHz., CCIR: 15.625 KHz. | | |
| Vertical Frequency | EIA: 60 Hz., CCIR: 50 Hz | | |
| Synchronization | Internal | | |
| Scanning System | 2 : 1 Interlace | | |
| Resolution | Horizontal 420 TV Lines | Horizontal 420 TV Lines | Horizontal 600 TV Lines |
| Sensitivity | 0.1 Lux @F2.0 | 0.1 Lux @F2.0 | 0.2 Lux @F2.0 |
| S/N Ratio | More than 48 dB (AGC Off) | | |
| Gain Control | Automatic Gain Control | | |
| Electronic Shutter | Auto: 1/60(50) sec. ~ 1/100,000 sec. | | |
| Gamma Correction | 0.45 | | |
| Video Output | 1.0 Vp-p Composite Video Output; 75 Ohms | | |
| Lens Built-in | 3.6mm/F2.0 Board Lens | | |
| Operating Temperature | - 10 ~ +50 degree C | | |
| Power Consumption | Max. 1.2 W | | |
| Power Supply | DC 12V | | |
| Dimension | 47.6mm x 53mm x 30mm | | |
| Weight | 180 grams | | |
| Optional Lens | | | |
| Board Lens | 2.5mm/4.3mm/6.0mm/8.0mm/12.0mm (Optional) | | |
| Pinhole Lens | 3.7mm/F2.0 or 4.3mm/F2.0 Cone-type Pinhole Lens | | |

Dimensions

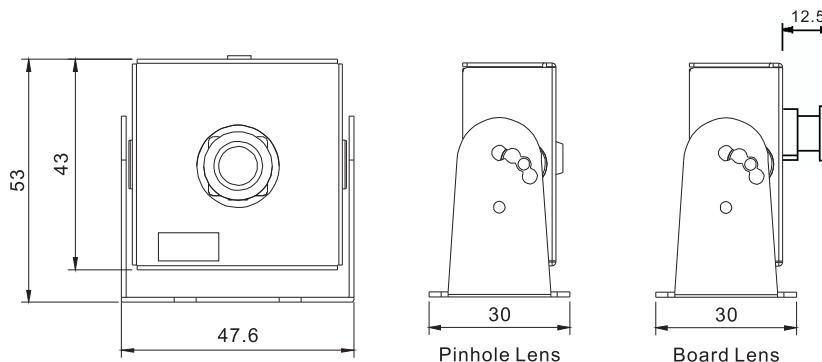

PTZ Speed Domes
Network Solutions
Dome Cameras
Board Cameras
Day/Night Cameras
Box Cameras

CCTV Equipment, Digital Storage & Network Solutions